

Redetermination of the Viscosity of Molten NaCl at Elevated Temperatures

T. Ito,¹ N. Kojima,¹ and A. Nagashima¹

Received October 17, 1988

The viscosity of molten sodium chloride (NaCl) has been measured in the temperature range 1083–1248 K by the oscillating-cup method. Although NaCl was considered as one of the standard salts, there existed a systematic deviation among the available data. The present measurement is the redetermination after checking the effects of the meniscus at the liquid surface and of the temperature field.

KEY WORDS: high temperature; molten salt; oscillation viscometer; sodium chloride; viscosity.

1. INTRODUCTION

Molten salts are the most important candidates for heat carriers, fuel solvents, or heat storage materials at high temperatures. These applications require the precise knowledge of their thermophysical properties. The viscosity, one of the most basic properties, not only is interesting scientifically but also is important for calculations of heat transfer and fluid dynamics. Although NaCl was considered as the standard salt, there existed a sizable discrepancy even among selected data by recent authors. In 1968, the first version of the recommendation of the viscosity of NaCl was determined by the Molten Salts Data Center and published by the NBS [1]. As explained by Janz [2, 3], this recommendation was revised in 1980 based mainly on the measurement by Torklep and Oye by the oscillating-cylinder method [4]. The revised recommendation was significantly lower than the first one. The present authors performed measurement of NaCl by the oscillating-cup method first in 1980 [5] and

¹ Department of Mechanical Engineering, Keio University, Hiyoshi, Yokohama 223, Japan.

obtained results which were systematically higher by about 6% than those of Torklep and Oye by the oscillating-cylinder method [4]. Torklep and Oye [6] claimed that the major source of this discrepancy would be the meniscus at the liquid surface in the oscillating-cup viscometer. But from the present authors' experience, the meniscus effect was different for different substances and for different conditions, and therefore, they considered that the discrepancy was too systematic for a single error source as the meniscus and that all possibilities on the oscillating-cup as well as the oscillating-cylinder viscometers should be rechecked. Meanwhile two new measurements by Ejima and co-workers, one by the capillary method [7] and the other by the oscillating-cup method [8], were reported. After analyzing all possible sources on the oscillating-cup method, we came to the conclusion that two error sources should be studied further, namely, the effects of the meniscus at the liquid surface and of the temperature distribution along the axis of the oscillation system. Since NaCl is one of the most important salts, we have performed redetermination of its viscosity after studying the two possible error sources mentioned above.

2. APPARATUS AND WORKING EQUATION

The experimental method and apparatus of the present study are similar to those described in Refs. [5, 9-10]. Figure 1 is a schematic

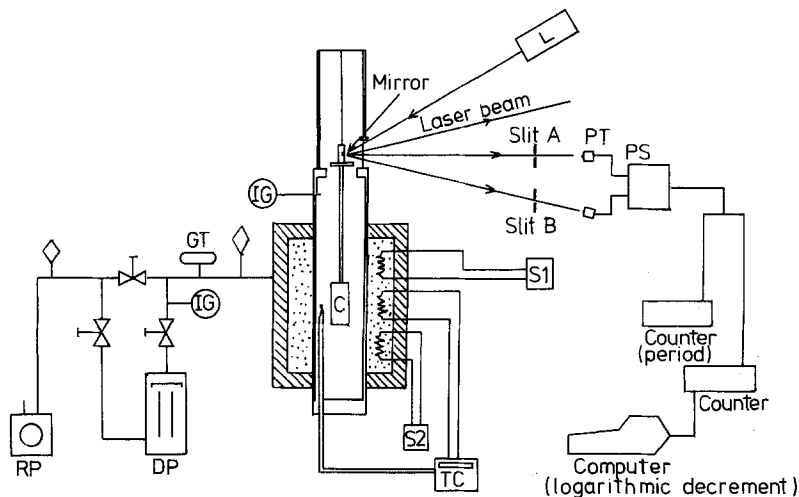

Fig. 1. Schematic diagram of the oscillating-cup viscometer. C, cup containing specimen; L, laser light source; PT, phototransistor; IG, ionization vacuum gage; TC, controller; RP and DP, rotary and diffusion vacuum pump; GT, Geissler tube; PS, trigger circuit, S, slide rheostat.

diagram of the oscillating-cup viscometer employed in the present study. The details of the viscometer are shown in Fig. 2. The viscometer consists essentially of an oscillating system with a thin Pt92% – W8% suspension wire of 0.2-mm-diameter and a hollow cylindrical cup which contains the specimen fluid. The cup was made of heat-resisting SUH3 steel for NaCl measurement and of SUS304 stainless steel for KNO₃ and water measurements. The fluid is tightly enclosed in the cup, and the inside of the viscometer is evacuated to exclude the influence of remaining gas on the suspension system. Once a torsional oscillation of the suspension system is started, the executed oscillation is gradually damped for a constant period and a constant logarithmic decrement and these two factors are determined by the viscosity and the density of the fluid, the moment of inertia of the system, and the geometrical dimensions of the cylindrical cup. The viscosity of the fluid enclosed in the cup is thus evaluated from the characteristic dimensions of the suspension system and the measurement of its torsional oscillation.

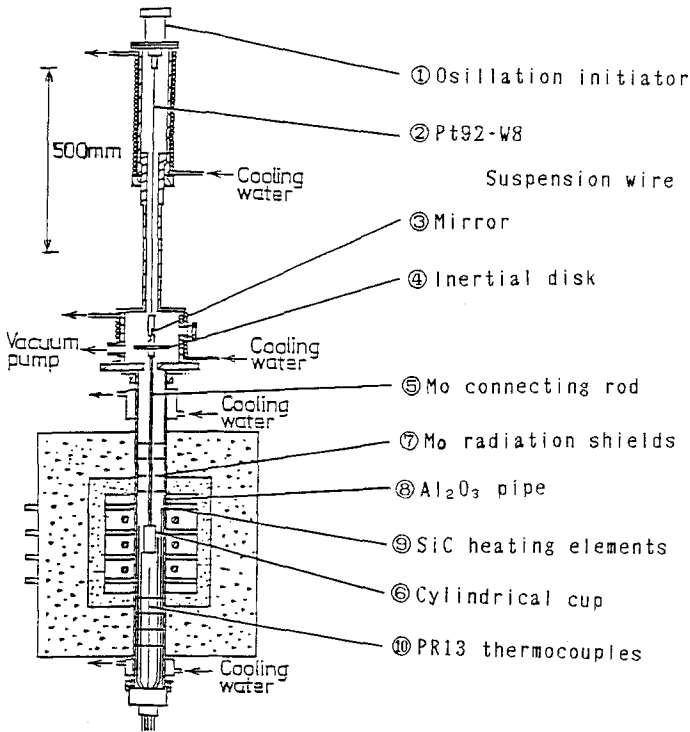

Fig. 2. Details of the viscometer.

The cup containing the specimen was heated up in the furnace of SiC resistors through the container wall. The heater system consisted of three parts; the middle part was controlled automatically at an aimed temperature, while the other two parts were used manually to adjust the temperature distribution. The temperature of the specimen inside the cup could not be measured directly but estimated from readings of five Pt-Pt13Rh thermocouples properly arranged around the cylindrical cup. Some more details regarding the temperature measurements are explained later.

For precise measurement of the period and the logarithmic decrement, an optical measuring system was used. The motion of the torsional oscillation of the cup was monitored by reflection of the He-Ne laser beam from a mirror attached to the suspension system. After passing the slit, the reflection from a mirror was transformed into an electric signal through a phototransistor and the intervals of two signals were measured by the universal counters. The period was determined as the time required for a reflection to pass through a slit located at the center of the oscillation. The decrement was determined from the difference between the successive times required for passing slits A and B.

The viscosity calculation was executed by using the imaginary part of a rigorous solution for the oscillating-cup viscometry derived by Kestin and Newell [11]. The equation is

$$(S + \Delta_0)^2 + 1 + D(S) = 0 \quad (1)$$

where $D(sd)$ is the characteristic function

$$D(S) = \frac{I'}{I} S^2 \sum_{n=1}^{\infty} \frac{8}{\mu_n^2} \left\{ 1 - \frac{S}{S_n^2} \left[1 - \frac{\tanh(S_n \zeta_0)}{S_n \zeta_0} \right] \right\} \quad (2)$$

S is the complex frequency

$$S = \frac{T_0}{T} (-\Delta \pm i) \quad (3)$$

and Δ , Δ_0 , S_n , ζ_0 , and ξ_0 are defined as

$$\Delta = \frac{\delta}{2\pi}, \quad \Delta_0 = \frac{\delta_0}{2\pi}, \quad S_n^2 = \frac{\mu_n^2}{\xi_0^2} + S,$$

$$\zeta_0 = h \sqrt{2\pi\rho/\eta T_0}, \quad \text{and} \quad \xi_0 = r \sqrt{2\pi\rho/\eta T_0}$$

In these equations, δ_0 denotes the logarithmic decrement of the suspension system without fluid, i.e., the intrinsic decrement observed with fluid, I' the moment of inertia of the system with fluid in the cup, I the moment of

inertia of the system without fluid, r the inner radius of the cup, h the height of the liquid column, η the viscosity, ρ the density, and μ_n the roots of the first-order Bessel function $J_1(\mu_n) = 0$, and T and T_0 are the periods of oscillation with and without fluid, respectively.

It is worth noting that the term $\sqrt{(\eta T_0/2\pi\rho)}$ is, in a sense, an average boundary layer thickness. The detail of the calculation process is similar to that explained in Ref. 5.

3. EXPERIMENTAL EXAMINATIONS OF THE MENISCUS EFFECT AND OF THE TEMPERATURE DISTRIBUTION

In the cell of the present apparatus, the specimen liquid was sealed in vacuum, in the solid state at first and in the liquid state in the measuring condition. The melt cannot be fully filled in the present system at high temperatures and therefore a free surface exists. As explained in the previous section, the calculation of the viscosity requires the value of the height of the liquid column. The most serious factors affecting the calculation of the height are the density of the liquid and the meniscus shape at the wall. The density is often known with a satisfactory reliability and cannot be the source of serious errors. In the case of the meniscus effect, not only the surface tension but also the wettability and the surface condition of the solid wall make the shape of the meniscus virtually unpredictable. The present authors consider that the best way to eliminate or to correct the error due to this effect is to repeat the measurement with a different height of the liquid column and to compare the result with that for the fully filled condition, the so-called full-cup condition. Neither theoretical estimation of the surface shape nor chemical cleaning of the surface can fully eliminate the error. In the present study, measurements were repeated for different heights for water at lower temperatures, molten KNO_3 at moderate temperatures, and molten NaCl at high temperatures. Since the full-cup measurement was possible only for water, the agreement between full-cup data and data extrapolated from height variation measurements were studied with water.

The cups used for these measurements are shown in Figs. 3 and 4. The cup for water was made of SUS304 stainless steel and sealed using a Teflon O-ring. The cups for KNO_3 and NaCl were made of SUS304 and of heat-resisting SUH3, steel respectively. They had similar dimensions and were sealed by electron beam welding after filling and evacuating. In the case of KNO_3 and NaCl, five to nine cups for each substance filled with different quantities of specimen were used in order to test for different heights of the liquid column. As an example, the characteristics of the suspension system

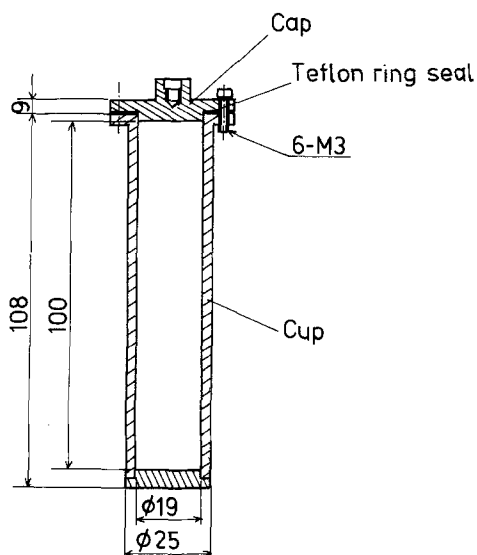

Fig. 3. Cup for the measurements on water.

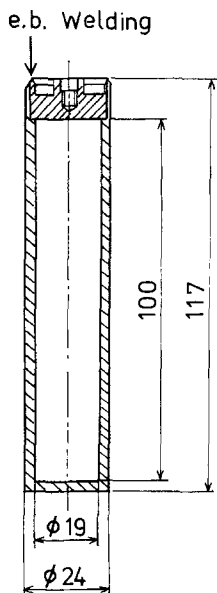

Fig. 4. Cup for the measurement on KNO_3 . For NaCl , similar cups with a length of 87 mm were used.

Table I. Characteristics of the Suspension System for NaCl Measurement

R (cm)	0.9502 ± 0.0005	(20°C)
I_0 (g · cm ²)	185.843 ± 0.056	(20°C)
T_0 (s)	5.90936 ± 0.00006	(20°C)
δ_0	0.00029	(810°C)

for NaCl measurement are shown in Table I. The densities of the specimens were calculated with the equation given by Kell [12] for water and the equations recommended by Janz [2] for KNO₃ and for NaCl. The results of the measurements with different heights of liquid are summarized in Fig. 5 as a deviation plot of the apparent viscosity. These deviations show differences of each measured viscosity from the reference viscosity equation by Nagashima [13] for water, from the measured data at the liquid height of 9 cm for KNO₃, and from the measured data at the liquid height of 6.5 cm for NaCl. The absolute value of the viscosity for KNO₃ was checked also with the recommendation of the Molten Salt Data Center [2]. For NaCl, the comparison of the absolute values is shown below.

The results for water showed a good agreement with those by Torklep and Oye [4]. But our repeated measurements for KNO₃ and NaCl did not show a fully good agreement with their results and this suggested the

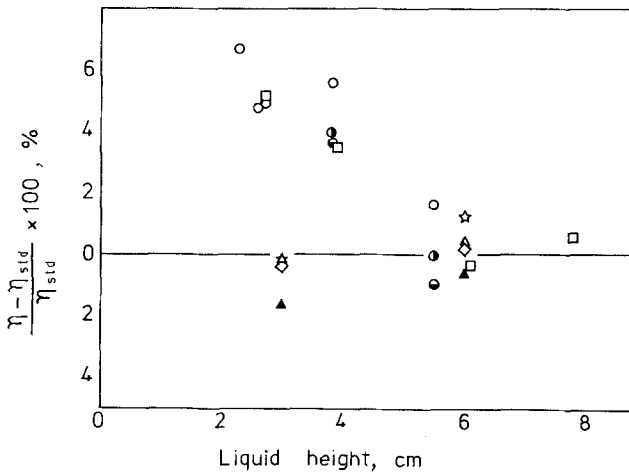

Fig. 5. Deviations of measured values with different heights of the liquid column. (□) H₂O (293 K); (◇) KNO₃ (623 K); (☆) KNO₃ (673 K); (△) KNO₃ (723 K); (▲) KNO₃ (773 K); (●) NaCl (1173 K); (●) NaCl (1223 K).

existence of a different effect for different combinations of substances and wall materials. The important conclusion with these measurements is that the measured values converge at a liquid height greater than approximately 6 cm in the case of the present system and the value measured at a height greater than 6 cm will not show the previously mentioned difference of existing data for NaCl, namely, 6%. This means that the meniscus effect can explain only partly the discrepancy between the data of Abe et al. [5] and those of Torklep and Oye [4].

Another possibility of the source of the disagreement in NaCl data is the temperature measurement reliability. In the present system, the suspension system is set to oscillate in vacuum in order to eliminate instability due to convection in the surrounding gas. The evacuation makes heat transfer between the cup and the container very small, especially at lower temperatures where radiation is not so significant. Since one end of the

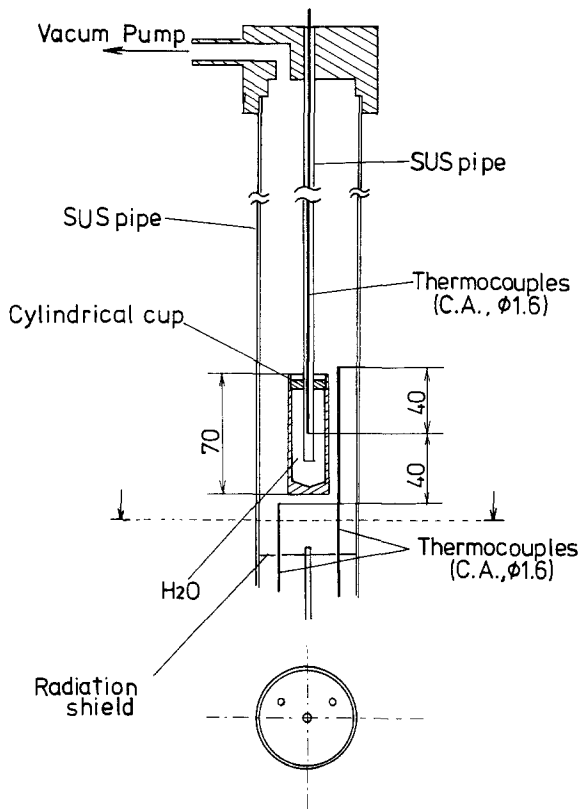

Fig. 6. Location of thermocouples in the temperature-check measurement.

oscillating system is kept at room temperature while the other is at a high temperature, there exists heat conduction through the stem. In the present study, the temperature-check measurement was performed by inserting a thermocouple into a cup as shown in Fig. 6. Also, the response time of the temperature inside the cup was measured. Three thermocouples were placed between the cup and the container as shown in Fig. 6. After performing measurements in the temperature range 400–975°C, a correction for temperature was determined and applied to the viscosity measurement. The correction was based on results as shown in Fig. 7, where ΔT , the temperature difference between the inside and the outside of the cup, was expressed as a function of the parameter defined as

$$\Delta T = 0.004(\lambda_{TC} A_{TC} \Delta T_{TC}) \tag{4}$$

where λ_{TC} is the effective thermal conductivity of a sheathed thermocouple in the axial direction, A_{TC} is the cross-sectional area of the thermocouple, and ΔT_{TC} is the temperature difference at two defined positions of each thermocouple. In order to prevent natural convection inside the cup, the temperature of the top of the cup was adjusted to be higher by about 1°C than that of the bottom.

At moderate temperatures, the test measurements were repeated with thermocouples which had surfaces of different colors, by applying a thin

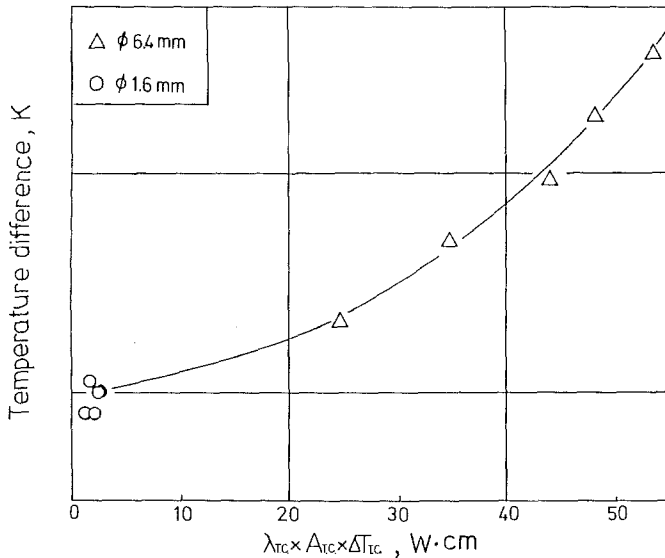

Fig. 7. Temperature correction curve. (Δ) Thermocouple diameter, 6.4 mm (sheath diameter); (\circ) thermocouple diameter, 1.6 mm.

layer of paint, in order to find the effect of different emissivities. The time lag of the inside temperature from the indication of thermocouples outside was less than 1 h. Every successive measurement of the viscosity in the present study was repeated after waiting at least 3 h. The experimental error of the present measurement was estimated as follows. The error in the viscosity due to the error in temperature measurement was $\pm 0.2\%$. The errors due to measurements of the decrement and the period were estimated as ± 1.0 and $\pm 0.01\%$, respectively. The purity of the NaCl sample was very high and the purity would not affect the viscosity results. The error due to uncertainties in the calculated density of NaCl and the thermal expansion coefficient of the cup materials was $\pm 0.16\%$. The error due to the meniscus effect was studied as explained in Section 3 and estimated as $\pm 2.1\%$, which included temperature error and so on. Therefore, considering all of these possibilities, the error in the viscosity of NaCl was estimated as $\pm 2.4\%$.

4. REDETERMINATION OF NaCl

After studying various possible error sources carefully, the viscosity of NaCl has been redetermined in the temperature range 1083–1248 K. This time the sampler used was the standard salt supplied by the Molten Salts Data Center at Rennselaer Polytechnic Institute (USA) by courtesy of Professor G. J. Janz. The sample was heated to 200°C and evacuated for 30 h. All handlings including weight measurement were performed in a nitrogen atmosphere. The sample was then filled into the cup under vacuum and sealed by electron beam welding.

Measured results are given in Table II. The viscosity η_{nom} means the value corrected to the nominal temperature T_{nom} . The following correlation represents the experimental data within 1%:

$$\eta = \sum_{i=0}^2 a_i T^{-i} \quad (5)$$

with $a_0 = 1.442784 \times 10^{-1}$, $a_1 = -3.998335 \times 10^2$, and $a_2 = 1.475991 \times 10^6$, yielding η in $10^{-3} \text{ Pa} \cdot \text{s}$ and T in K. All of the important experimental data including those of Smirnov et al. [14] and Brockner et al. [15] are compared in Fig. 8. The data from the present study are lower than our previous data [5] but the deviation is less at higher temperatures. The reason for this trend is probably the smaller temperature error at higher temperatures in the previous study since radiation heat transfer is dominant at high temperatures. The present results are about 3% higher than those of Torklep and Oye by the oscillating-cylinder method [4] and of Ejima et al. by the capillary method [7]. The latest data of Ejima et al.

Table II. Experimental Results for NaCl

T (K)	η (10^{-3} Pa · s)	T_{nom} (K)	η_{nom} (10^{-3} Pa · s)
1082.3	1.029	1083	1.028
1082.3	1.025		1.023
1082.4	1.027		1.025
1082.5	1.029		1.028
1094.2	1.016	1094	1.016
1094.1	1.017		1.017
1094.1	1.020		1.020
1102.6	0.996	1103	0.996
1102.5	1.004		1.003
1102.4	1.004		1.003
1103.2	0.996		0.997
1103.2	0.996		0.997
1103.1	1.003		1.003
1122.0	0.961	1123	0.959
1122.0	0.959		0.957
1122.0	0.959		0.957
1147.6	0.912	1148	0.911
1147.8	0.914		0.914
1147.7	0.915		0.914
1147.9	0.914		0.914
1147.8	0.921		0.921
1147.8	0.914		0.914
1172.5	0.872	1173	0.871
1172.4	0.875		0.874
1172.3	0.873		0.872
1172.0	0.878		0.877
1172.3	0.874		0.874
1171.9	0.875		0.874
1197.6	0.842	1198	0.842
1197.3	0.841		0.840
1197.3	0.838		0.837
1197.8	0.844		0.844
1197.7	0.839		0.839
1197.8	0.837		0.836
1222.5	0.805	1223	0.804
1222.4	0.805		0.804
1222.4	0.805		0.804
1248.3	0.771	1248	0.771
1248.3	0.773		0.773
1248.3	0.774		0.775

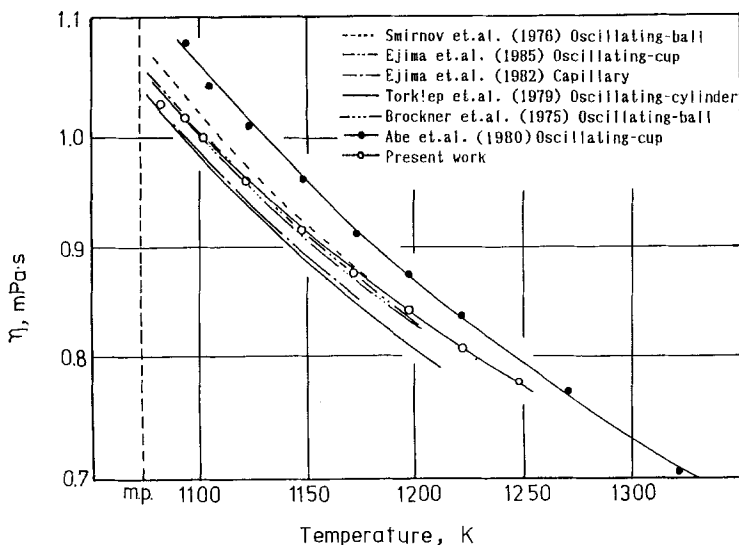

Fig. 8. Viscosity of NaCl reported in the literature.

by the oscillating-cup method [8] agree well with the present results. In conclusion, the present authors consider that Eq. (23) represents the most probable values of the viscosity of molten NaCl in the temperature range from the melting point to 1500 K.

ACKNOWLEDGMENTS

The present authors are grateful to Professor G. J. Janz of Rensselaer Polytechnic Institute for kindly supplying the standard NaCl sample to the authors. Assistance in the measurements and in the preparation of the manuscript by Messrs. Y. Uota and K. Minami is also acknowledged.

REFERENCES

1. G. J. Janz, F. W. Dampier, G. R. Lakshminarayanan, P. K. Lorentz, and R. P. T. Tomkins, *Molten Salts: Viscosity Data* (NSRDS, NBS, 1968), p. 48.
2. G. J. Janz, *J. Phys. Chem. Ref. Data* **9**:791 (1980).
3. G. J. Janz, *Proc. 8th Symp. Thermophys. Prop. Vol. II* (ASME, New York, 1982), p. 256.
4. K. Torklep and H. A. Oye, *Ber. Bunsenges. Phys. Chem.* **83**:1 (1979).
5. Y. Abe, O. Kosugiyama, and A. Nagashima, *Ber. Bunsenges. Phys. Chem.* **84**:1178 (1980).
6. K. Torklep and H. A. Oye, *Ber. Bunsenges. Phys. Chem.* **85**:814 (1981).
7. T. Ejima, K. Shimakage, Y. Sata, H. Okuda, N. Kumada, and A. Ishigaki, *J. Chem. Soc. Jap.* 961 (1982).

8. T. Ejima, Y. Sato, and E. Takeuchi, *6th Japan. Symp. Thermophys. Prop., Sendai* (1985), p. 69.
9. Y. Abe, O. Kosugiyama, and A. Nagashima, *J. Nucl. Mater.* **99**:173 (1981).
10. Y. Abe, O. Kosugiyama, H. Mitajima, and A. Nagashima, *J. Chem. Soc. Faraday I* **76**:2531 (1980).
11. J. Kestin and G. F. Newell, *Z. angew. Meth. Phys.* **8**:433 (1957).
12. G. S. Kell, *J. Chem. Eng. Data* **20**:97 (1975).
13. A. Nagashima, *J. Phys. Chem. Ref. Data* **6**:1133 (1977).
14. M. V. Smirnov, V. A. Khokhlov, and A. A. Antonov, *Trudi Inst. Elektrokhim. Ural. Nauch. Tsentr AN SSSR* **24**:10 (1976).
15. W. Brockner, K. Grjotheim, T. Ohta, and H. A. Oye, *Ber. Bunsenges. Phys. Chem.* **79**:344 (1975).